

# VIKING PRODUCT MANUAL

COMMUNICATION &amp; SECURITY SOLUTIONS

ADA Compliant VoIP  
Emergency Phones

March 27, 2015

## ADA Compliant VoIP Emergency Phones with Built-In Dialer and Digital Voice Announcer

The **1600-IP Series** ADA Compliant VoIP Emergency Phones are designed to provide quick and reliable handsfree communication for SIP VoIP phone systems with PoE. All **1600-IP Series** phones meet ADA requirements for elevator/ emergency telephones, and can be programmed from any Touch Tone phone or PC on the same LAN. The phones can dial up to 5 programmable emergency numbers. In addition, the **E-1600-20-IP** and **E-1600-52-IP** feature a second "INFO" button that will dial up to 5 non-emergency numbers.

The **1600-IP Series** phones can be programmed to automatically deliver a digital announcement to identify the location of the emergency call. Alternatively, a DTMF Touch Tone code may also be delivered. A "Call Connected" LED can be initiated manually or automatically. All programming parameters, including phone numbers and location numbers, are stored in non-volatile memory, requiring no batteries. All units are PoE powered.

For outdoor installations where the unit is exposed to precipitation or condensation, select **1600-IP Series** phones are available with Enhanced Weather Protection (**EWP**). EWP products feature foam rubber gaskets and boots, sealed connections, gel-filled butt connectors, as well as urethane or thermal plastic potted circuit boards. For more information, see **DOD# 859**.

**⚠ Installation requires the assistance of a Network Administrator / IT Technician.**

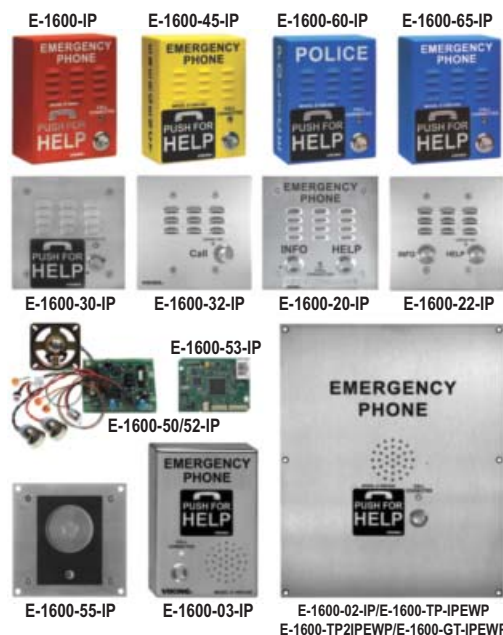

### Features

- Self diagnostic reports via email (testing com, mic, speaker & switch)
- Automatic polling and programming software included
- 2 Amp relay contacts for door/gate or SL-2 strobe light control
- SIP compatible (see pg 2 for list of compatible IP-PBX phone systems)
- PoE powered (class 1, <4 watts)
- Automatic Noise Canceling (ANC) feature for proper operation in noisy environments
- VoIP eliminates the need for "Push to Talk" mode
- Network downloadable firmware
- Meets ADA requirements for Emergency Phones:
  - Automatically lights the "Call Connected" LED
  - Transmits a unique location I.D. code or voice announcement
  - Grade 2 Braille label for the visually impaired
- Non-volatile digital voice announcer with 28 seconds of voice memory
- Handsfree operation
- Marine grade 316 stainless steel prevents corrosion on the stainless steel models
- Dials up to 5 emergency numbers
- **E-1600-20-IP** and **E-1600-52-IP** dial up to 5 non-emergency "INFO" numbers
- Cycles through backup phone numbers on busy or no-answer
- Optional Enhanced Weather Protection (EWP), EWP products are designed to meet IP66 Ingress Protection Rating, see **DOD# 859**
- Hangs up on busy signal, time-out or touch tone command
- Remotely programmable
- Extended temperature range (-30°F to 130°F)
- 11 different chassis or board only available
- Available in 42" tower phone model **E-1600-BLTIPEWP (DOD# 217)**
- Optional **PB-100** Polling System available (**DOD# 232**)
- Optional **SL-2** or **BLK-4-EWP** strobe light kit available (**DOD# 242/653**)
- Optional **E-1600A-MK-GNP** Pedestal Mounting Kit (**DOD# 227**)

### Applications

- Elevators
- Parking ramps/lots
- Emergency pool phones
- ATM machines
- Area of refuge locations
- Medical centers
- Lobbies
- Entryways
- Campus emergency stations
- Stadiums
- Convention centers
- Public access areas

*\* Americans with Disabilities Act of 1992 contains federal regulations regarding elevator telephones (Public Law 101-336).*

**www.vikingelectronics.com**  
**Information: (715) 386-8861**

### Specifications

**Power:** PoE class 1 (<4 watts)  
**Dimensions:** See Installation and Specifications  
**Operating Temperature:** -34° C to 54° C (-30°F to 130°F)  
**Humidity - Standard Products:** 5% to 95% non-condensing  
**Humidity - EWP Products:** Up to 100%  
**Audio Codecs:** G711u, G711a, G722  
**Connections:** (1) RJ45 10/100 Base-T, (3) gel-filled butt connectors

## Viking VoIP SIP System Compatibility List

**NOTE:** Exclusion from this list means only that compatability has not been verified, **it does not mean incompatability.**

For detailed configuration instructions for certain vendors below, see **Configuring Viking VoIP Phone and SIP Servers, DOD# 944.**

Vendor	Infrastructure Class				
	Softswitch	PBX	Proxy	SBC (session border controller)	Service Provider
3COM VCX		X			
3CX		X			
Aastra		X			
Asterisk		X			
Atcom		X			
Avaya IP Office		X			
BlueBox		X			
Brekeke		X			
Cisco Unified Communications Manager (CUCM)	X	X			
Cisco Unified Communications Manager Express (CUCME)	X	X			
Freeswitch		X			
Grandstream		X			
iptel.org					X
Kamailio			X	X	
MetaSwitch				X	X
OfficeSIP		X			
OpenSIPS		X			
Panasonic		X			
Samsung Communications Manager (SCM)	X	X			
ShoreTel		X			
Siemens Communications Server (SCS)		X			
SIP Express Router (SER)			X	X	
sip.antisip.com					X
Snom PBX		X			
Sonus				X	
Switchvox		X			X
Teksip			X		
Toshiba		X			
VoIP.ms					X

# Overview of Chassis and Mounting Options



**Model: E-1600-53-IP**  
**Description:** 1600-IP board (PCB) only kit. Can be used to convert any analog Viking 1600A-Series phone to a VoIP version



**Model: E-1600-20-IP**  
**HxWxD:** 5.0 x 5.0 x 2.25  
**Mounting:** Flush mount with included rough-in box (will not fit in a double gang box), or surface mount with a VE-5x5  
**Description:** Two button, 14 gauge marine grade 316 stainless steel, #4 brushed finish



**Model: E-1600-IP**  
**HxWxD:** 5.25 x 4.0 x 2.0  
**Mounting:** Surface mount  
**Description:** 16 gauge steel with textured red powder paint



**Model: E-1600-22-IP**  
**HxWxD:** 5.0 x 5.0 x 2.25  
**Mounting:** Flush mount in a standard double gang electrical box or surface mount with a VE-5x5  
**Description:** Two button, 14 gauge marine grade 316 stainless steel with #4 brushed finish



**Model: E-1600-45-IP**  
**HxWxD:** 5.25 x 4.0 x 2.0  
**Mounting:** Surface mount  
**Description:** 16 gauge steel with textured yellow powder paint



**Model: E-1600-30-IP**  
**HxWxD:** 5.0 x 5.0 x 2.25  
**Mounting:** Flush mount with included rough-in box (will not fit in a double gang box), or surface mount with a VE-5x5  
**Description:** 14 gauge marine grade 316 stainless steel, #4 brushed finish



**Model: E-1600-60-IP**  
**HxWxD:** 5.25 x 4.0 x 2.0  
**Mounting:** Surface mount  
**Description:** 16 gauge steel with textured blue powder paint and "POLICE" verbiage



**Model: E-1600-32-IP**  
**HxWxD:** 5.0 x 5.0 x 2.25  
**Mounting:** Flush mount in a standard double gang electrical box or surface mount with a VE-5x5  
**Description:** 14 gauge marine grade 316 stainless steel, #4 brushed finish



**Model: E-1600-65-IP**  
**HxWxD:** 5.25 x 4.0 x 2.0  
**Mounting:** Surface mount  
**Description:** 16 gauge steel with textured blue powder paint

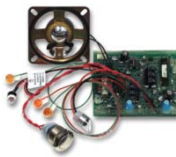

**Model: E-1600-50-IP**  
**Description:** Single button 1600-IP parts kit without chassis

**Model: E-1600-52-IP**  
**Description:** Two button 1600-IP parts kit without chassis



**Model: E-1600-55-IP**  
**HxWxD:** 5.0 x 5.0 x 2.0  
**Description:** Universal emergency phone kit to install behind elevator panels or when a custom panel is used



**Model: E-1600-03-IP**  
**HxWxD:** 7.22 x 5.36 x 1.55  
**Mounting:** Surface mount  
**Description:** 14 gauge marine grade 316 stainless steel with #4 brushed finish



**Model: E-1600-02-IP**  
**HxWxD:** 13.0 x 10.5 x 2.0  
**Mounting:** Flush mount  
**Description:** 12 gauge marine grade 316 stainless steel with #4 brushed finish



**Model: E-1600-TP-IPEWP**  
**HxWxD:** 11.75 x 9.5 x 2.0  
**Mounting:** Flush mount  
**Description:** Direct physical replacement for Talk-A-Phone model ETP-400V



**Model: E-1600-TP2IPEWP**  
**HxWxD:** 11.75 x 9.5 x 2.0  
**Mounting:** Flush mount  
**Description:** Direct physical replacement for Talk-A-Phone model ETP-400DV

# Definitions

**Client:** A computer or device that makes use of a server. As an example, the client might request a particular file from the server.

**DHCP:** Dynamic Host Configuration Protocol. In this procedure the network server or router takes note of a client's MAC address and assigns an IP address to allow the client to communicate with other devices on the network.

**DNS Server:** A DNS (Domain Name System) server translates domain names (ie: www.vikingelectronics.com) into an IP address.

**Ethernet:** Ethernet is the most commonly used LAN technology. An ethernet Local Area Network typically uses twisted pair wires to achieve transmission speeds up to 1Gbps.

**Host:** A computer or device connected to a network.

**Host Name:** A host name is a label assigned to a device connected to a computer network that is used to identify the device in various forms of network communication.

**Hosts File:** A file stored in a computer that lists host names and their corresponding IP addresses with the purpose of mapping addresses to hosts or vice versa.

**Internet:** A worldwide system of computer networks running on IP protocol which can be accessed by individual computers or networks.

**IP:** Internet Protocol is the set of communications conventions that govern the way computers communicate on networks and on the Internet.

**IP Address:** This is the address that uniquely identifies a host on a network.

**LAN:** Local Area Network. A LAN is a network connecting computers and other devices within an office or building.

**Lease:** The amount of time a DHCP server reserves an address it has assigned. If the address isn't used by the host for a period of time, the lease can expire and the address can be assigned to another host.

**MAC Address:** MAC stands for Media Access Control. A MAC address, also called a hardware address or physical address, is a unique address assigned to a device at the factory. It resides in the device's memory and is used by routers to send network traffic to the correct IP address. You can find the MAC address of your 1600-IP Series phone printed on a white label on the top surface of the PoE LAN port.

**Router:** A device that forwards data from one network to another. In order to send information to the right location, routers look at IP Address, MAC Address and Subnet Mask.

**RTP:** Real-Time Transport Protocol is an Internet protocol standard that specifies a way for programs to manage the real-time transmission of multimedia data over either unicast or multicast network services.

**Server:** A computer or device that fulfills requests from a client. This could involve the server sending a particular file requested by the client.

**Session Initiation Protocol (SIP):** Is a signaling communications protocol, widely used for controlling multimedia communication sessions such as voice and video calls over Internet Protocol (IP) networks. The protocol defines the messages that are sent between endpoints, which govern establishment, termination and other essential elements of a call.

**Static IP Address:** A static IP Address has been assigned manually and is permanent until it is manually removed. It is not subject to the Lease limitations of a Dynamic IP Address assigned by the DHCP Server. The default static IP Address is: 192.168.154.1

**Subnet:** A portion of a network that shares a common address component. On TCP/IP networks, subnets are defined as all devices whose IP addresses have the same prefix. For example, all devices with IP addresses that start with 100.100.100. would be part of the same subnet. Dividing a network into subnets is useful for both security and performance reasons. IP networks are divided using a subnet mask.

**TCP/IP:** Transmission Control Protocol/Internet Protocol is the suite of communications protocols used to connect hosts on the Internet. TCP/IP uses several protocols, the two main ones being TCP and IP. TCP/IP is built into the UNIX operating system and is used by the Internet, making it the de facto standard for transmitting data over networks.

**TISP:** Telephone Internet Service Provider

**WAN:** Wide Area Network. A WAN is a network comprising a large geographical area like a state or country. The largest WAN is the Internet.

**Wireless Access Point (AP):** A device that allows wireless devices to connect to a wired network using Wi-Fi, or related standards. The AP usually connects to a router (via a wired network) as a standalone device, but it can also be an integral component of the router itself.

**Wireless Repeater (Wireless Range Extender):** takes an existing signal from a wireless router or access point and rebroadcasts it to create a second network. When two or more hosts have to be connected with one another over the IEEE 802.11 protocol and the distance is too long for a direct connection to be established, a wireless repeater is used to bridge the gap.

# Features Overview

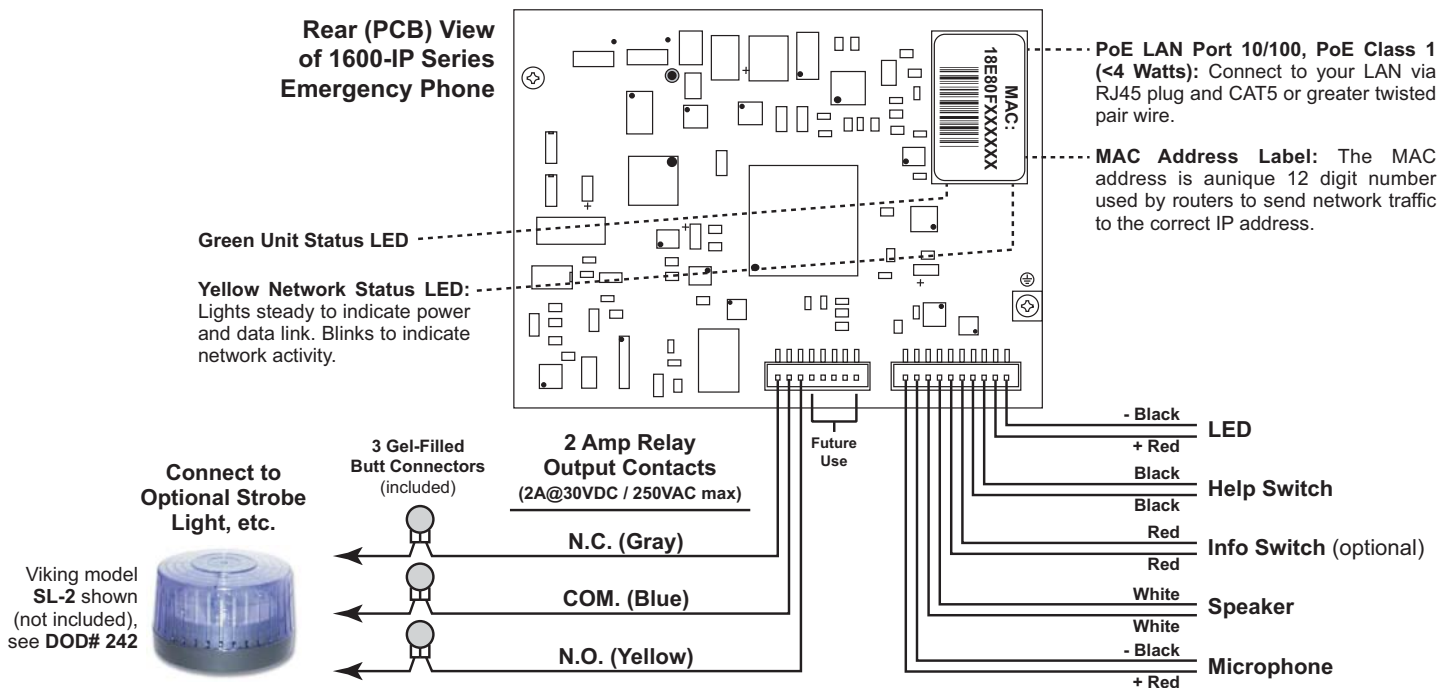

# Installation and Specifications

The following sections show specifications and installation instructions for the different chassis in the 1600-IP Series.

**⚠ IMPORTANT:** Electronic devices are susceptible to lightning and power station electrical surges from both the AC outlet and the telephone line. It is recommended that a surge protector be installed to protect against such surges.

## E-1600-IP / E-1600-45-IP / E-1600-60-IP / E-1600-65-IP

**Optional Enhanced Weather Protection (EWP) Available\***

**Dimensions:** 133mm x 102mm x 51mm (5.25" x 4.0" x 2.0")

**Shipping Weight:** 1.13 kg (2.5 lbs.)

**Material:** .062" (16 gauge) steel

**Finish:** E-1600-IP - Red powder paint, E-1600-45-IP - Yellow powder paint,

E-1600-60/65-IP - Blue powder paint

**Connections:** Gel-filled butt connectors

**Mounting:** Surface mount to walls, posts, single gang boxes or 4" x 4" electrical junction boxes or recess mount in elevator phone boxes.

**\*Optional Enhanced Weather Protection (EWP):** The optional EWP products feature foam rubber gaskets and boots, sealed connections, gel-filled butt connectors, as well as urethane or thermal plastic potted circuit boards. See **DOD# 859**.  
**Note:** For greater weather resistance, apply a bead of clear silicone caulking around the top edge and sides of the chassis.

**Optional Gooseneck Pedestal Mounting Kit:** The E-1600A-MK-GNP Mounting Kit (**DOD# 227**) allows you to mount the E-1600-IP, E-1600-45-IP, E-1600-60-IP or E-1600-65-IP to a Viking VE-GNP Gooseneck Pedestal (**DOD# 424**).

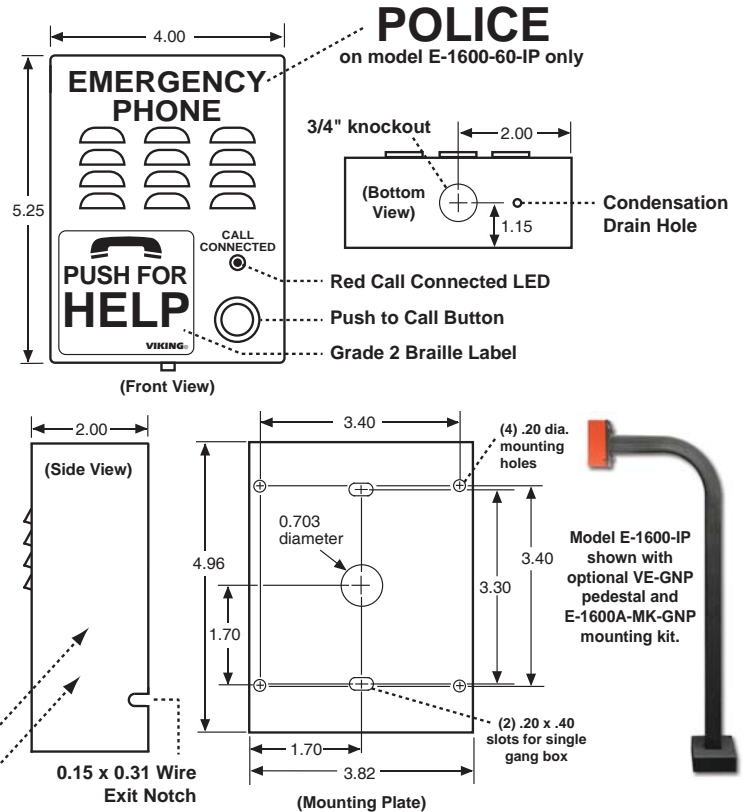

## E-1600-02-IP

**Optional Enhanced Weather Protection (EWP) Available\***

**Dimensions:** 330mm x 267mm x 51mm (13" x 10.5" x 2")

**Shipping Weight:** 3.18 kg (7 lbs.)

**Connections:** Gel-filled butt connectors

**Material:** .125" (11 gauge) brushed stainless steel  
**Mounting:** Flush mount in elevator cabs, ATMs, stairwells, hallways, etc.

**Suggested Hardware:** (6) #8 x 3/4 flat head phillips sheet metal type A screws (not included)

**\*Optional Enhanced Weather Protection (EWP):** The optional EWP products feature foam rubber gaskets and boots, sealed connections, gel-filled butt connectors, as well as urethane or thermal plastic potted circuit boards. See **DOD# 859**.

**Note:** When mounting outside to rough or uneven surfaces (brick, stucco, etc.) apply a bead of clear silicone caulking around the top edge and sides of faceplate.

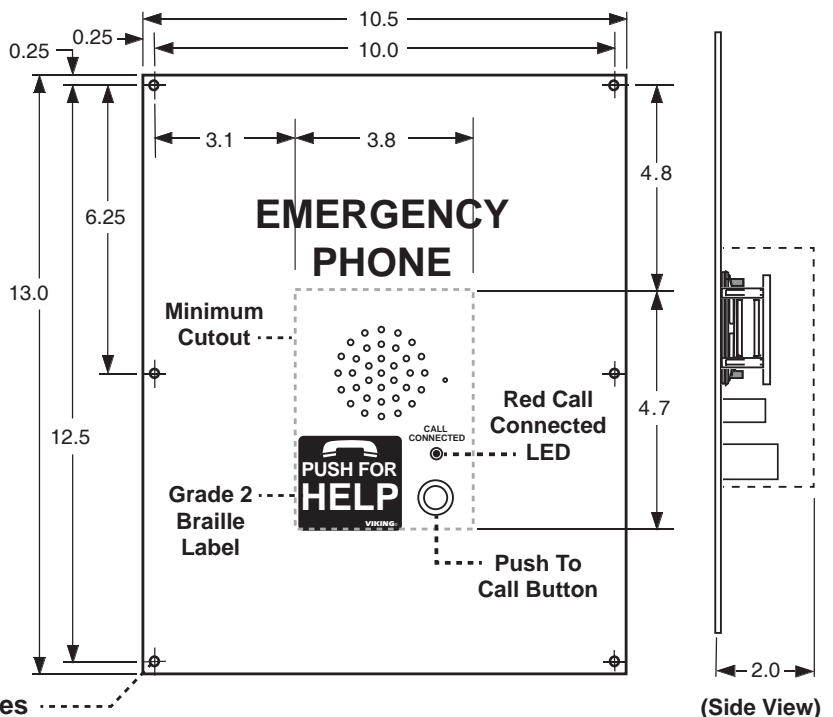

## E-1600-03-IP

### Optional Enhanced Weather Protection (EWP) Available\*

**Dimensions:** 183mm x 149mm x 39mm (7.22" x 5.36" x 1.55")

**Material:** 14 gauge Marine grade 316 brushed stainless steel panel

**Shipping Weight:** 1.36 kg (3 lbs.)

**Connections:** Gel-filled butt connectors

**Mounting:** Surface mount to walls, posts, single gang boxes, double gang boxes or 4" x 4" electrical junction boxes or recess mount in elevator phone boxes.

**\*Optional Enhanced Weather Protection (EWP):** The optional EWP products feature foam rubber gaskets and boots, sealed connections, gel-filled butt connectors, as well as urethane or thermal plastic potted circuit boards. See **DOD# 859**.

**Note:** For greater weather resistance, apply a bead of clear silicon caulking around the top edge and sides of the chassis.

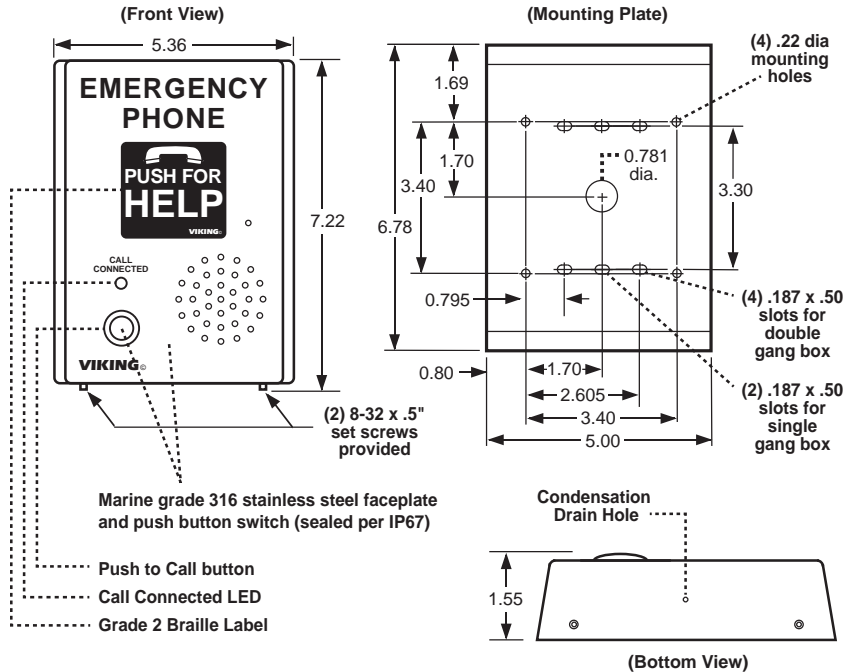

## E-1600-20-IP

### Optional Enhanced Weather Protection (EWP) Available\*

**Dimensions:** Overall - 127mm x 127 x 57mm (5.0" x 5.0" x 2.25"), Plastic Electrical Box - 102mm x 102mm x 54mm (4.0" x 4.0" x 2.14")

**Shipping Weight:** 1 kg (2.12 lbs.)

**Front Panel Material:** 14 gauge Marine grade 316 brushed stainless steel

**Connections:** Gel-filled butt connectors

**\*Optional Enhanced Weather Protection (EWP):** The optional EWP products feature foam rubber gaskets and boots, sealed connections, gel-filled butt connectors, as well as urethane or thermal plastic potted circuit boards. See **DOD# 859**.

**Mounting with Plastic Rough-In Box (included):** Flush into walls, mounts to side of wall stud. **Mounting with Optional VE-5x5:** Surface mount to walls, single gang boxes, double gang boxes, posts, or to a Viking **VE-GNP** Gooseneck pedestal (see **DOD# 424** for more information).

**Note:** When mounting outside to rough or uneven surfaces (brick, stucco, etc.) apply a bead of clear silicone caulking around the top edge and sides of faceplate or **VE-5x5**.

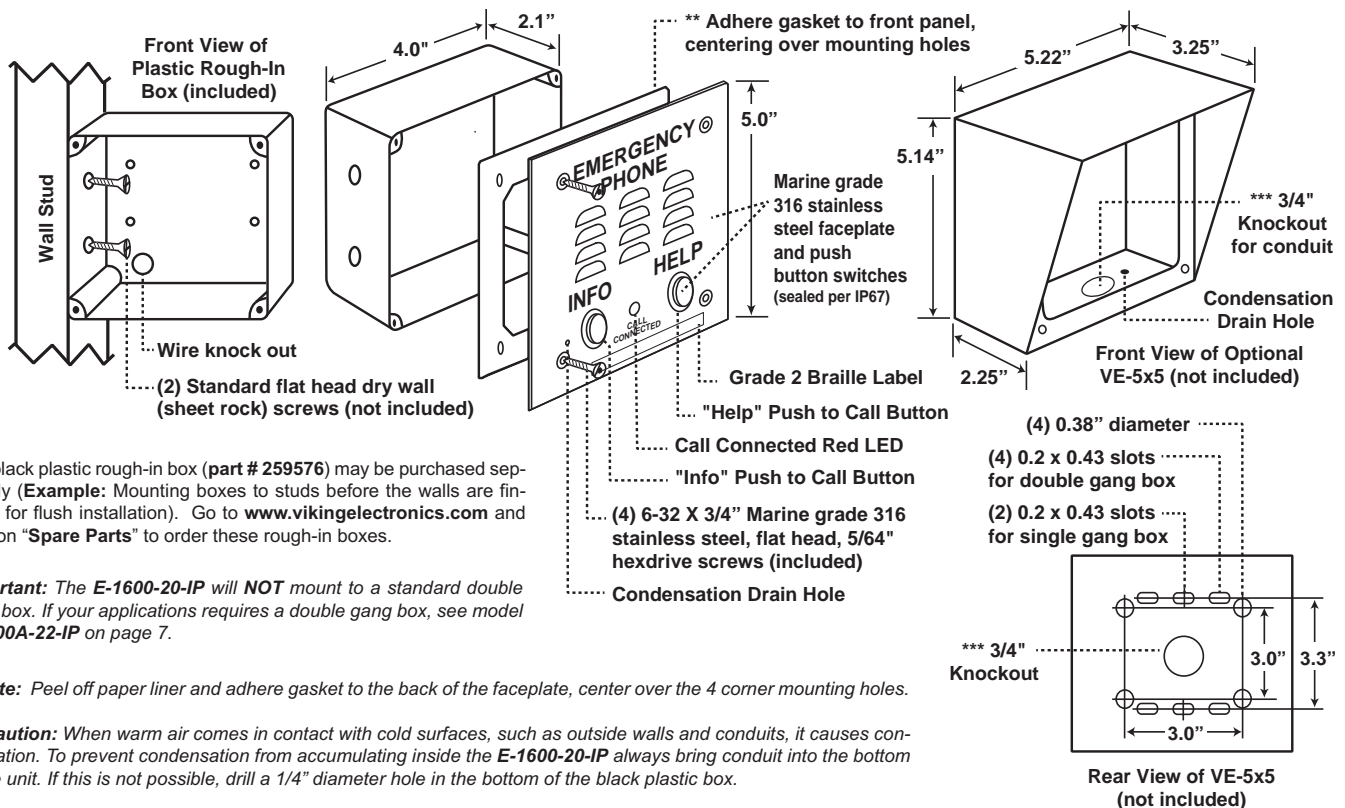

The black plastic rough-in box (part # 259576) may be purchased separately (Example: Mounting boxes to studs before the walls are finished for flush installation). Go to [www.vikingelectronics.com](http://www.vikingelectronics.com) and click on "Spare Parts" to order these rough-in boxes.

**Important:** The **E-1600-20-IP** will **NOT** mount to a standard double gang box. If your applications requires a double gang box, see model **E-1600A-22-IP** on page 7.

**\*\* Note:** Peel off paper liner and adhere gasket to the back of the faceplate, center over the 4 corner mounting holes.

**\*\*\* Caution:** When warm air comes in contact with cold surfaces, such as outside walls and conduits, it causes condensation. To prevent condensation from accumulating inside the **E-1600-20-IP** always bring conduit into the bottom of the unit. If this is not possible, drill a 1/4" diameter hole in the bottom of the black plastic box.

## E-1600-22-IP / E-1600-32-IP

### Optional Enhanced Weather Protection (EWP) Available\*

**Dimensions:** Overall - 127mm x 127 x 57mm (5.0" x 5.0" x 2.25")

**Shipping Weight:** 1 kg (2.12 lbs.)

**Front Panel Material:** 14 gauge Marine grade 316 brushed stainless steel

**Connections:** Gel-filled butt connectors

**\*Optional Enhanced Weather Protection (EWP):** The optional EWP products feature foam rubber gaskets and boots, sealed connections, gel-filled butt connectors, as well as urethane or thermal plastic potted circuit boards. See **DOD# 859**.

**Mounting in a Double Gang Rough-In Box (not included):** Flush into walls, mounts to side of wall studs, etc. **Mounting with Optional VE-5x5:** Surface mount to walls, single gang boxes, double gang boxes, posts, or to a Viking **VE-GNP** Gooseneck pedestal (see **DOD# 424** for more information).

**Note:** When mounting outside to rough or uneven surfaces (brick, stucco, etc.) apply a bead of clear silicone caulking around the top edge and sides of faceplate or **VE-5x5**.

**\*\* Note:** Peel off paper liner and adhere gasket to the back of the faceplate, centering it over the mounting holes.

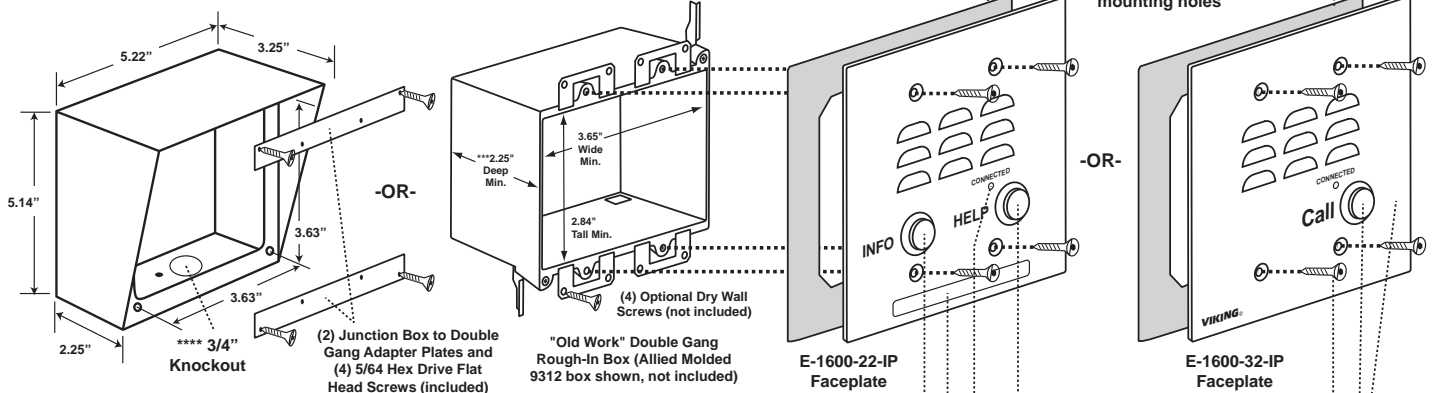

Optional VE-5x5 Surface Mount Box with black satin powder paint finish, not included (DOD# 424). Optional VE-LIGHT kit can be used to illuminate the faceplate when used with a VE-5x5 (DOD# 428). **WARNING: Do NOT use a wet location box.**

**\*\*\* CAUTION:** Excessive wire length and/or using a rough-in box with inadequate depth can apply force to the circuit board causing physical damage.

**\*\*\*\* CAUTION:** When warm air comes in contact with cold surfaces, such as outside walls and conduits, it causes condensation. To prevent condensation from accumulating inside the **E-1600-22-IP** or **E-1600-32-IP** always bring conduit into the bottom of the unit. If this is not possible, drill a 1/4" diameter hole in the bottom of the black plastic box.

"Info" Push to Call Button (E-1600-22-IP only)  
Grade 2 Braille Label  
Call Connected Red LED  
"Help" Push to Call Button

(4) 6-32 X 3/4" Marine grade 316 stainless steel, flat head, 5/64" hexdrive screws (included)

Marine grade 316 stainless steel faceplate and push button switches (sealed per IP67)

## E-1600-30-IP

### Optional Enhanced Weather Protection (EWP) Available\*

**Dimensions:** Overall - 127mm x 127 x 57mm (5.0" x 5.0" x 2.25"), Plastic Electrical Box - 102mm x 102mm x 54mm (4.0" x 4.0" x 2.14")

**Shipping Weight:** 1 kg (2.12 lbs.)

**Front Panel Material:** 14 gauge Marine grade 316 brushed stainless steel

**Connections:** Gel-filled butt connectors

**\*Optional Enhanced Weather Protection (EWP):** The optional EWP products feature foam rubber gaskets and boots, sealed connections, gel-filled butt connectors, as well as urethane or thermal plastic potted circuit boards, **DOD# 859**.

**Mounting with Plastic Rough-In Box (included):** Flush into walls, mounts to side of wall stud. **Mounting with Optional VE-5x5:** Surface mount to walls, single gang boxes, double gang boxes, posts, or to a Viking **VE-GNP** Gooseneck pedestal.

**Note:** When mounting outside to rough or uneven surfaces (brick, stucco, etc.) apply a bead of clear silicone caulking around the top edge and sides of faceplate or **VE-5x5**.

**Important:** The **E-1600-30-IP** will **NOT** mount to a standard double gang box. If your applications requires a double gang box, see model **E-1600A-32-IP** above.

**\*\* Note:** Peel off paper liner and adhere gasket to the back of the faceplate, center over the mounting holes.

**\*\*\* Important:** Optional Braille "Push for Help" label should be adhered to the faceplate in ADA applications. Clean surface with isopropyl alcohol, peel off backing and press firmly to the front panel in location as shown above.

**\*\*\*\* CAUTION:** When warm air comes in contact with cold surfaces, such as outside walls and conduits, it causes condensation. To prevent condensation from accumulating inside the **E-1600-30-IP** always bring conduit into the bottom of the unit. If this is not possible, drill a 1/4" diameter hole in the bottom of the black plastic box.

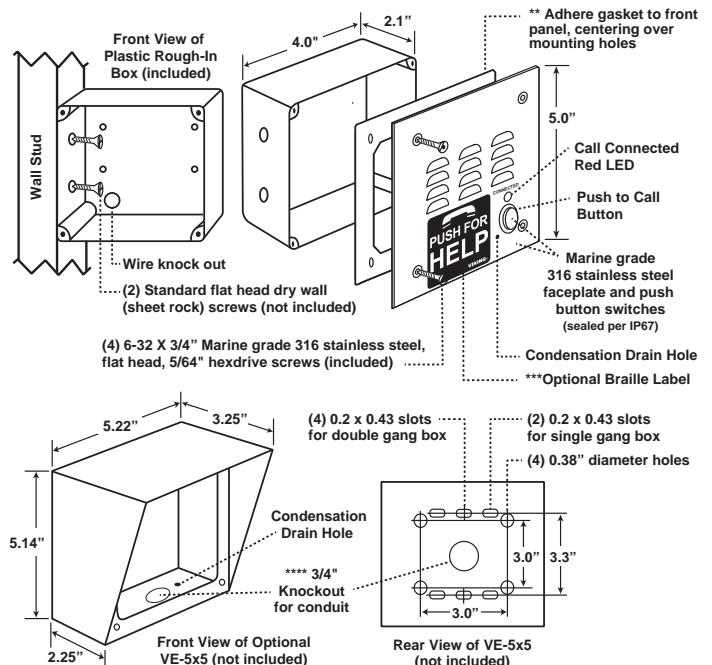

# E-1600-50-IP / E-1600-52-IP

## Optional Enhanced Weather Protection (EWP) Available\*

**Note:** This is a 1600-IP parts kit without chassis.

**Shipping Weight:** .45 kg (1 lb)  
**Connections:** Gel-filled butt connectors

**\*Optional Enhanced Weather Protection (EWP):** The optional EWP products feature foam rubber gaskets and boots, sealed connections, gel-filled butt connectors, as well as urethane or thermal plastic potted circuit boards. See **DOD# 859**.

**Important:** If installing the EWP version outdoors, apply a non-corrosive silicone to back side of LED after making all connections and testing.

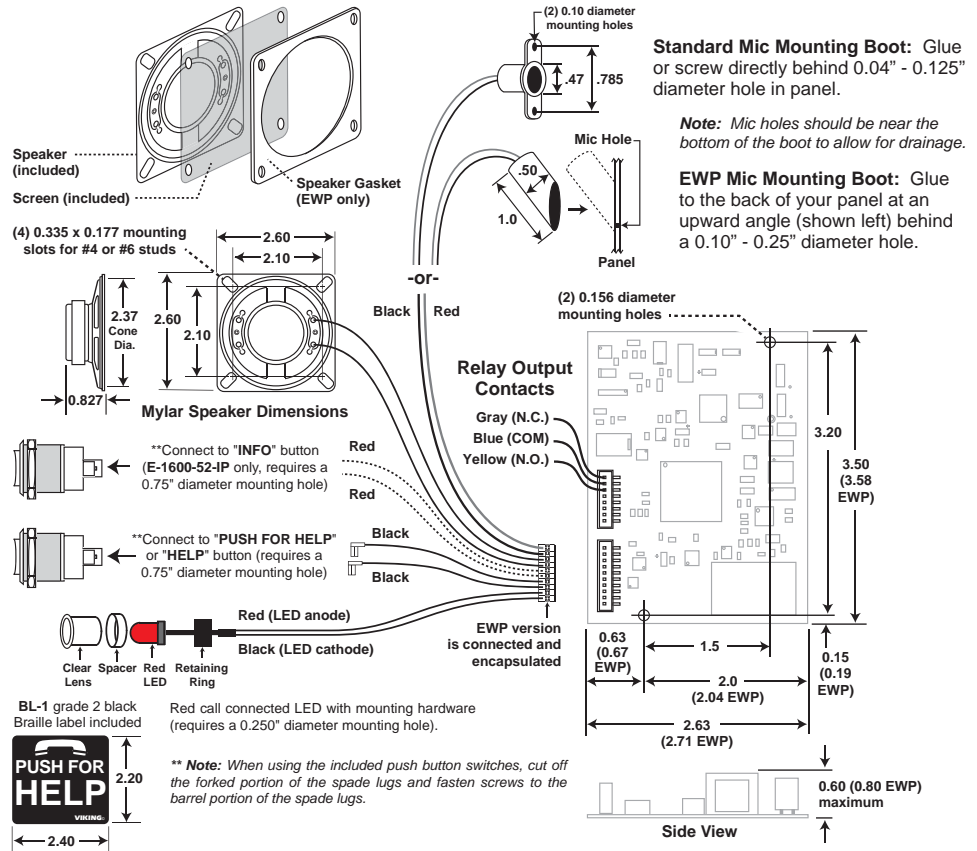

# E-1600-53-IP

## Optional Enhanced Weather Protection (EWP) Available\*

**Note:** This is a 1600-IP board (PCB) only kit. This kit can be used to convert any Viking 1600A Series analog emergency phone to a VoIP version. The kit can also be used to replace a damaged board in the field.

**Shipping Weight:** .45 kg (1 lb)  
**Connections:** (1) RJ45 10/100 Base-T, (3) optional gel-filled butt connectors, (10) additional gel-filled butt connectors included with EWP version only.

**\*Optional Enhanced Weather Protection (EWP):** The optional EWP products feature foam rubber gaskets and boots, sealed connections, gel-filled butt connectors, as well as urethane or thermal plastic potted circuit boards. See **DOD# 859**.

## Replacing Analog 1600A Series EWP Potted Circuit Boards:

<b>Step 1.</b>	Cut wires from J1 (10 pin connector) and J2 (2 pin connector).
<b>Step 2.</b>	Remove the two #6 phillips screws fastening the circuit board.
<b>Step 3.</b>	Cut off any stripped wire ends from the replacement cable.
<b>Step 4.</b>	Using the supplied gel-filled butt connectors, connect corresponding wires from replacement cable to the previously cut wires from the LED, Help/Call switch, optional Info switch, Speaker and Microphone. See <b>FIGURE 1</b> for wire color and polarity.

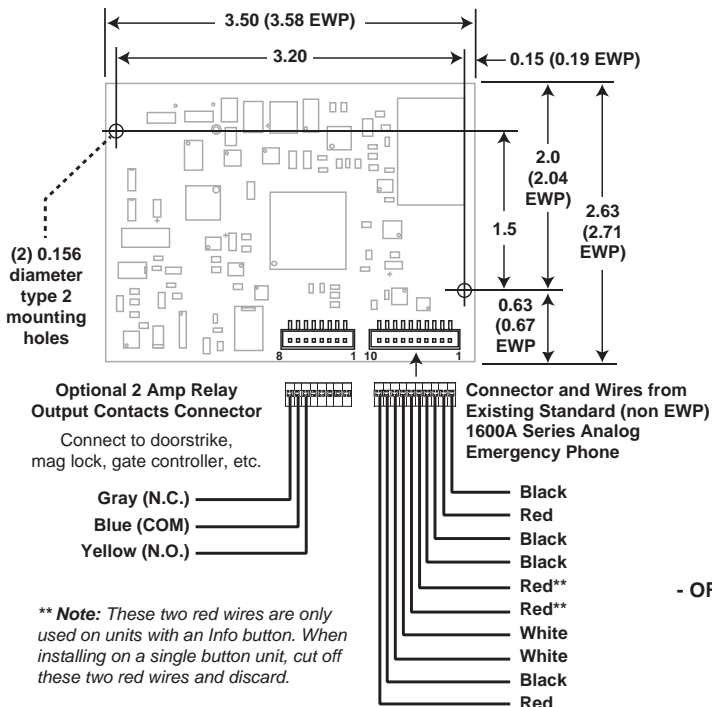

**FIGURE 1**  
 Replacement Cable Assembly (included)

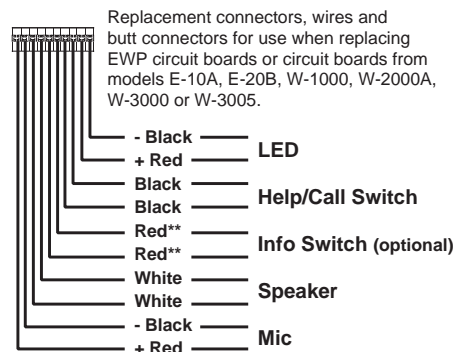



# E-1600-55-IP

## Optional Enhanced Weather Protection (EWP) Available\*

The E-1600-55-IP is a universal emergency phone kit for installing behind elevator panels, or an installation requiring a custom panel. The finished panel should provide: (4) studs (#6 diameter minimum) for mounting plate, audio holes for speaker and microphone, a momentary SPST push button switch and a 0.25" diameter mounting hole for the LED. Alternatively, the LED can be cut off and the wires connected to a integral switch with LED (often found in elevators).

**\*Optional Enhanced Weather Protection (EWP):** The optional EWP products feature foam rubber gaskets and boots, sealed connections, gel-filled butt connectors, as well as urethane or thermal plastic potted circuit boards. See **DOD# 859**.

**Shipping Weight:** .73 kg (1.6 lb)

**Connections:** (1) RJ45 10/100 Base-T, (5) gel-filled butt connectors

**Material:** 0.062" thick (16 gauge) zinc plated steel

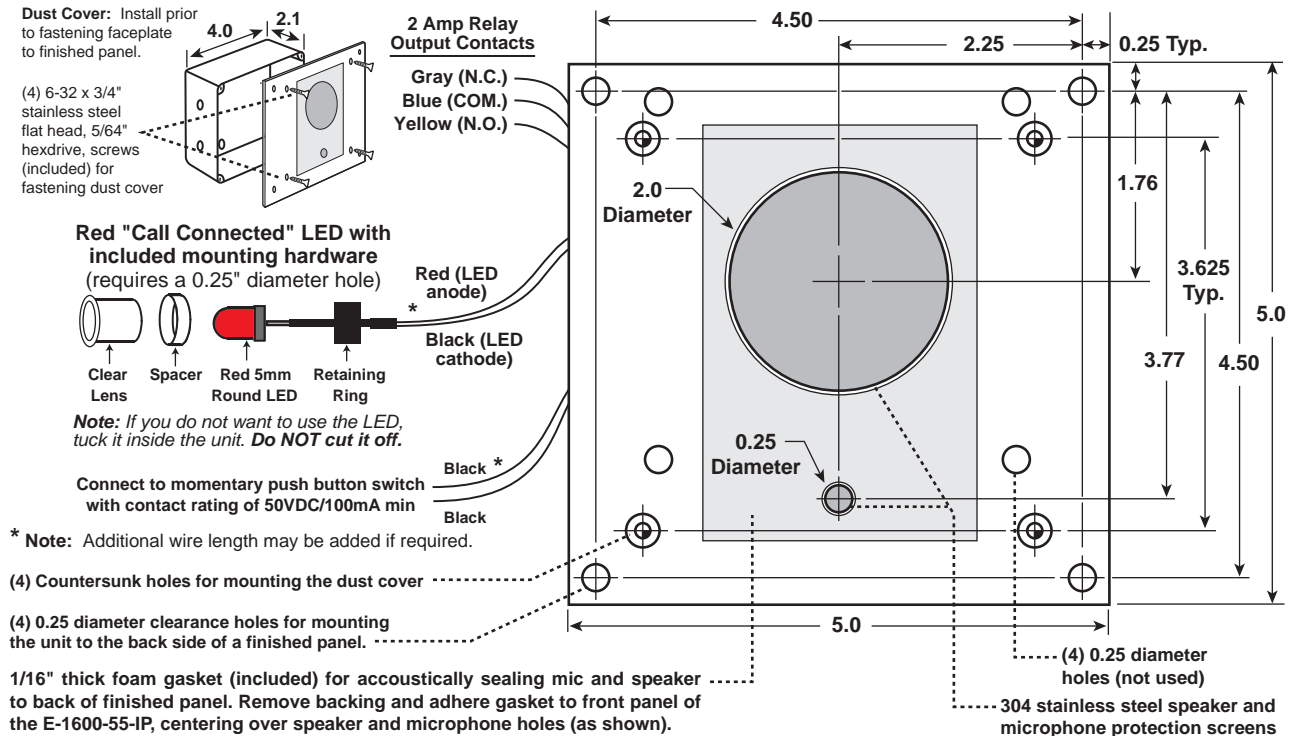

# E-1600-TP-IP-EWP / E-1600-TP2-IP-EWP

**Dimensions:** 241mm x 299mm x 51mm (9.5" x 11.75" x 2")

**Shipping Weight:** 2.9 kg (6.4 lbs)

**Mounting:** Flush mount to Talk-A-Phone ETP towers, wall mounts, boxes and pedestals

**Material:** .105" (12 gauge) brushed Marine grade 316 stainless steel

**Connections:** (1) RJ45 10/100 Base-T, color-coded wires with gel-filled butt connectors

**Enhanced Weather Protection (EWP):** EWP products feature foam rubber gaskets and boots, sealed connections, gel-filled butt connectors, as well as urethane or thermal plastic potted circuit boards. See **DOD# 859**.

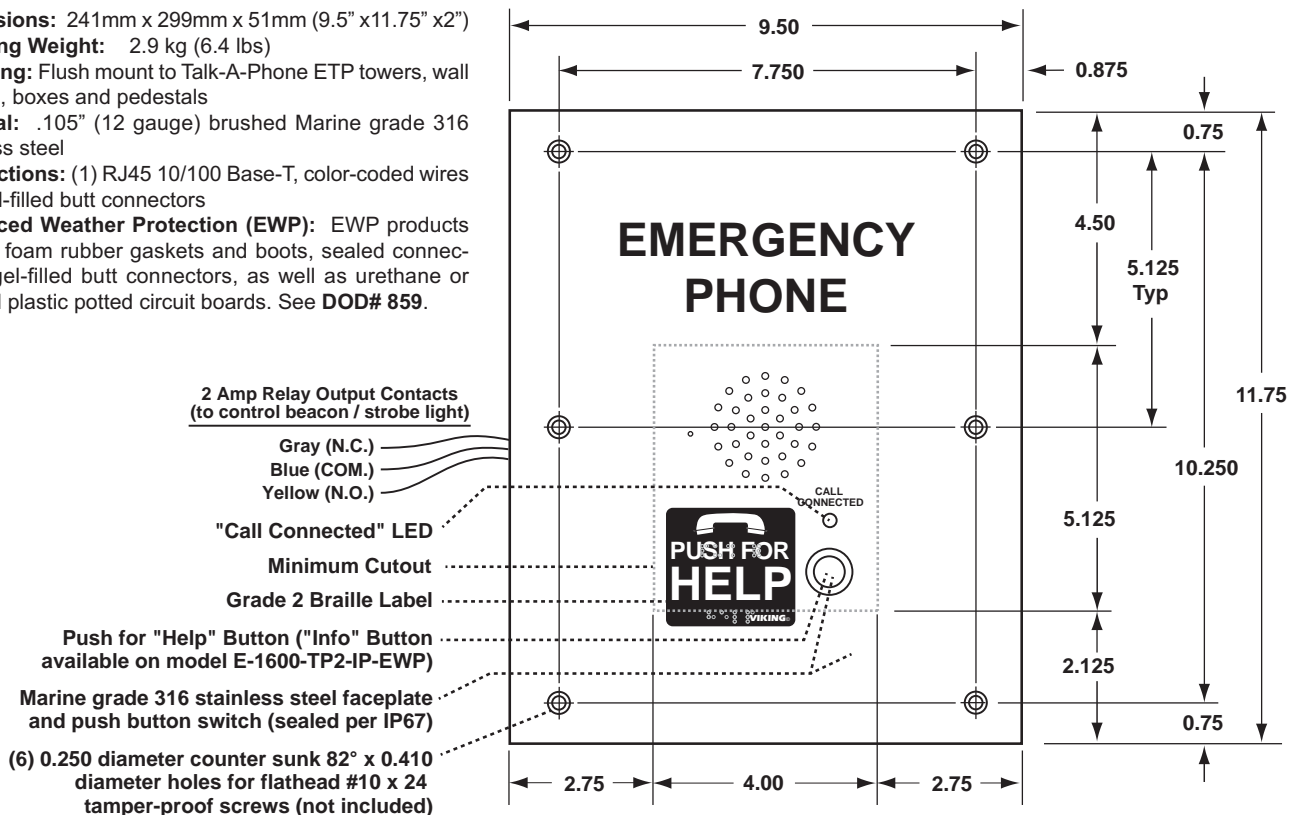

## Typical Installation on SIP Based VoIP Phone System

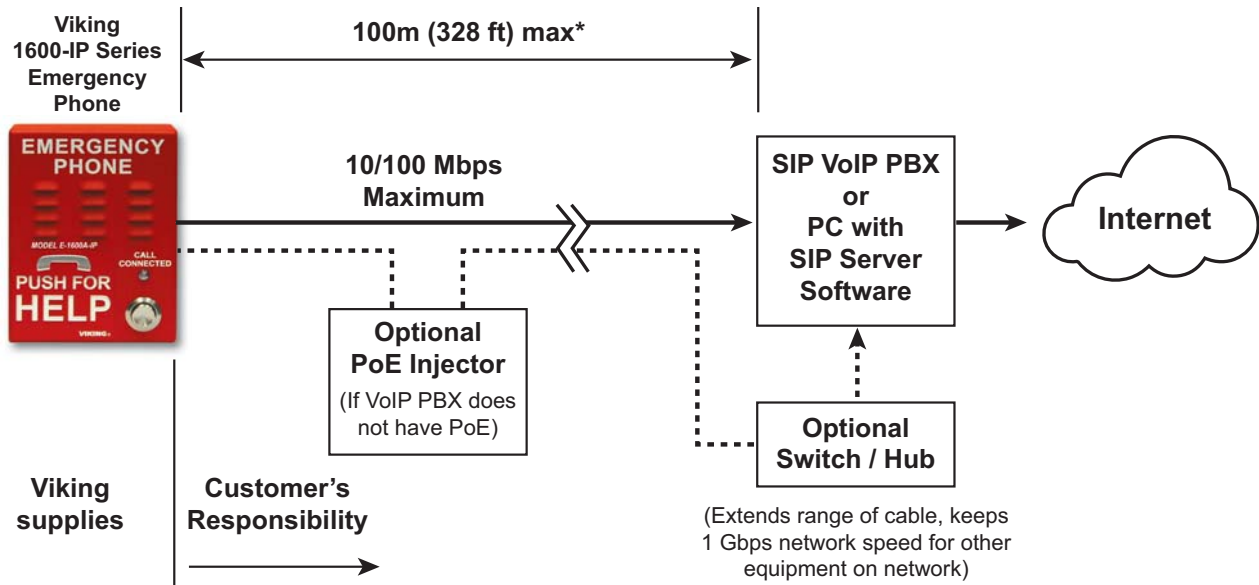

\* **Note:** A PoE extender can be used for an additional 100 meters per extender. For longer runs (up to 2 km / 1.2 miles) a ethernet to fiber media converter can be used.

## Typical Installation on SIP Based VoIP Phone System

- IBM compatible personal computer with:
  - Windows 2000 (service pack 4 or higher)
  - Windows XP (service pack 2 or higher)
  - Windows Vista (SP2 or newer), 32 or 64 bit versions
  - Windows 7
  - Windows 8
- Adobe Acrobat Reader 8 or higher
- **1600-IP Series** hardware
- Available LAN with PoE (class 1, <4 watts)
- Ethernet cable (CAT5 min.)
- 1 MB minimum free hard drive space for installation
- 16MB of free physical RAM

## PC Programming

A CD is included with each **1600-IP Series** VoIP phone. The CD contains the application "**Viking VoIP Phone Programming**" used to program the unit using a PC running Windows 2000, XP, Vista, Windows 7, or Windows 8 (see System Requirements above). The PC must be connected to the same LAN as the **1600-IP** VoIP phone. Install the application on your PC by placing the CD into your PC's drive. Click "I Accept" on the bottom of the first screen, then select "Viking VoIP Phone Programming" and click the "Install" button. Follow the directions on the screen. If you are reinstalling the Viking VoIP Phone Programming software you must uninstall the original version first via "Add and Remove Programs". To start the Viking VoIP Phone Programming application, click on the Viking VoIP Phone Programming icon on your desk top. The Main screen will appear, allowing the user to program any **1600-IP** phone connected to that LAN.

### A. Manually Muting SIP/Network Failure Alarm Beeps (3 beeps repeated every 30 seconds)

With the unit connected and powered (Green LED on and Yellow LED off or blinking) it will output 3 beeps every 30 seconds and turn the Call/Call Connected LED on and off once per second indicating a SIP registration failure, failure to ping gateway or Ethernet connection failure. You can manually disable the beeps by pressing and holding the Call button for 5 seconds (2 beeps will then be heard) or by clicking the "Mute Alarm Until Next Failure" tab in the Viking VoIP programming software. The LED will continue to flash allowing you to trouble shoot the failure.

### B. Configuring the 1600-IP Series Network Settings

<b>Step 1.</b>	Open the "Viking VoIP Phone Programming" software on a windows PC that is connected to the same LAN as the <b>1600-IP</b> phone to be programmed. The default static IP Address is: <b>192.168.154.1</b>
<b>Step 2.</b>	The window in the upper left corner of the menu will show you each <b>1600-IP</b> phone that is connected to that LAN. Select the unit with the same MAC address shown on the label located on the top of the Ethernet connector on the <b>1600-IP</b> phone.
<b>Step 3.</b>	Click the "Connect" button. If a pop up window appears, enter the unit's security code (factory set to <b>845464</b> ) then click the "OK" button.
<b>Step 4.</b>	The program will then read and display the <b>1600-IP</b> phone's IP and programming settings.
<b>Step 5.</b>	After adjusting the IP and phones settings, click the "Write" button under each column of settings to send the programming commands to the connected unit.

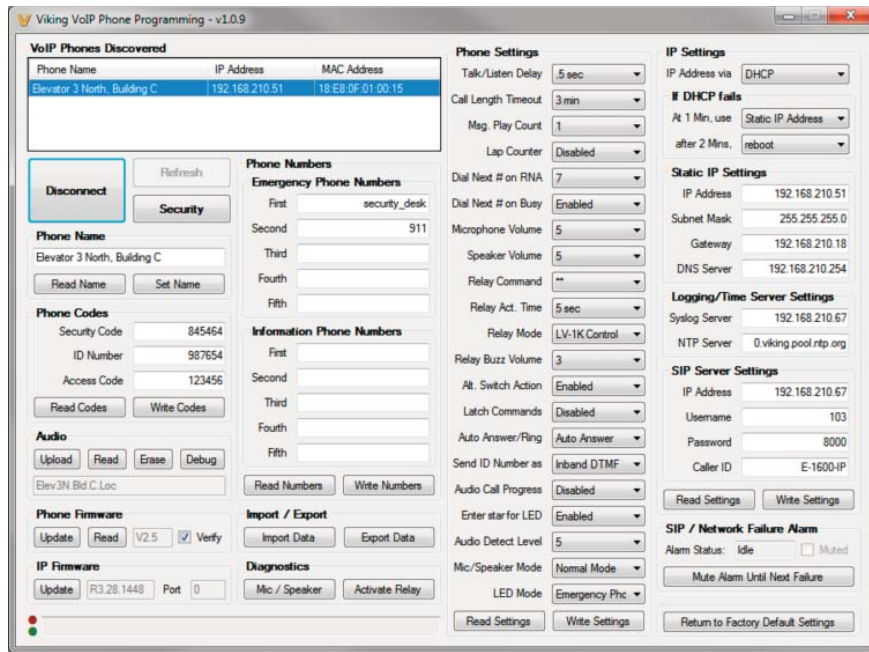

## C. Manually Resetting All Network Parameters to Factory Default

<b>Step 1.</b>	Power down the <b>1600-IP Series</b> phone by disconnecting the RJ45 plug.
<b>Step 2.</b>	Press and hold the HELP/CALL button, then reconnect the RJ45.
<b>Step 3.</b>	Continue to hold the button until you hear 2 beeps, (approximately 6 seconds). Continue to hold the button until you hear 4 more beeps, approximately 6 seconds later, then release the button. The “Call Connected” LED will remain off for the first 3 seconds, flash slowly for 3 seconds (2 beeps), fast flash for 6 seconds (4 beeps), then light steady indicating when to release button.
<b>Step 4.</b>	The unit should continue to output double beeps and slowly flash the LED indicating all Network Parameters are now reset to factory default. The default static IP Address is: <b>192.168.154.1</b>
<b>Step 5.</b>	You must now power cycle the unit by momentarily disconnecting the RJ45.
<b>Step 6.</b>	You will be required to re-enter your initial network settings prior to any touch tone programming, see section A on page 9.

# Touch Tone Programming

## A. Accessing the Touch Tone Programming Mode

The **1600-IP Series** emergency phones can be programmed by calling the unit from any touch tone phone.

### 1. Using the Security Code to Enter Programming

<b>Step 1.</b>	From a touch tone phone call the <b>1600-IP Series</b> phone you would like to program.
<b>Step 2.</b>	When the <b>1600-IP Series</b> phone answers, enter the 6-digit security code (factory set to <b>845464</b> , see section B). A double beep should then be heard indicating you have entered the programming mode.
<b>Step 3.</b>	You can now touch tone program the <b>Quick Programming Features</b> listed on page 10.

### 2. Manually Resetting the Security Code to Enter Programming

<b>Step 1.</b>	Power down the <b>1600-IP Series</b> phone by disconnecting the RJ45 plug.
<b>Step 2.</b>	Press and hold the HELP/CALL button, then reconnect the RJ45.
<b>Step 3.</b>	Continue to hold the button until you hear 2 beeps, (approximately 6 seconds). Then release the button. The “Call Connected” LED will remain off for the first 3 seconds, flash slowly for 3 seconds then fast flash (after 2 beeps) indicating when to release button.
<b>Step 4.</b>	The security code is now reset to <b>845464</b> (factory default).
<b>Step 5.</b>	You can now enter touch tone programming by following the steps in section 1. <b>Using the Security Code</b> , above.

## B. Security Code (#19)

The security code allows the user/installer to program the **1600-IP Series** phone. The factory set security code is 845464 (V-I-K-I-N-G). It is recommended that the factory set security code be changed. **Note:** *The security code must be 6 digits and cannot include a \* or a #.*

**Example:** To store 123456 as the security code (shown right).

<b>Step 1.</b>	Access programming as shown in <b>Programming</b> section A.
<b>Step 2.</b>	Enter <b>123456 #19</b> .
<b>Step 3.</b>	Hang-up.

## Quick Programming Features (after accessing the Touch Tone Programming Mode)

DESCRIPTION	DIGITS	+	MEMORY LOCATION
First emergency speed dial number	0-20 digits	then	#00
Second emergency speed dial number	0-20 digits	then	#01
Third emergency speed dial number	0-20 digits	then	#02
Fourth emergency speed dial number	0-20 digits	then	#03
Fifth emergency speed dial number	0-20 digits	then	#04
First "Info" speed dial number (E-1600-20/22/52/53-IP only)	0-20 digits	then	#05
Second "Info" speed dial number (E-1600-20/22/52/53-IP only)	0-20 digits	then	#06
Third "Info" speed dial number (E-1600-20/22/52/53-IP only)	0-20 digits	then	#07
Fourth "Info" speed dial number (E-1600-20/22/52/53-IP only)	0-20 digits	then	#08
Fifth "Info" speed dial number (E-1600-20/22/52/53-IP only)	0-20 digits	then	#09
To clear any speed dial number	(no digits)	then	#00 - #09
Talk/Listen Delay (.1 to .9 sec, factory set to .5 sec)	1 digit (1-9)	then	#11
Call Length Time Out (0 to 9 min, 0 = disabled, factory set to 3 min)	1 digit (0-9)	then	#12
Message Play Count (0 to 9, 0 = play every 8 sec, factory set to 1)	1 digit (0-9)	then	#15
Lap Counter (0 to 9, 0 = disabled, factory set to 0)	1 digit (0-9)	then	#16
Dial Next Number on Ring No Answer (0 or 1 = disabled, 2 - 9 = number of rings, factory set to 7)	1 digit (0-9)	then	#17
Dial Next Number on Busy (0 or 1, 0 = disabled, factory set to 1/enabled)	1 digit (0 or 1)	then	#18
Security code (factory set to 845464)	6 digits (0-9)	then	#19
Identification number (factory set to 987654)	6 digits (0-9)	then	#20
Access Code (1-6 digits, blank = disabled, factory set to 123456)	1-6 digits (0-9)	then	#21
Mic volume (0-9, 0 = ANC, factory set to 5)	1 digit (0-9)	then	#22
Speaker Volume (0-9, factory set to 5)	1 digit (0-9)	then	#23
Relay Activation Command ( 1 or 2 digits, **** = **, ***# = ##, 0-9 or 00-99, factory set to **) (Relay Mode must be set to 0 = Door Strike)	1 or 2 digits	then	#24
Relay Activation Time (2 digits, 00-99 sec, 00= 0.5 sec, factory set to 05)	2 digits (00-99)	then	#25
Relay Mode (0 = Door Strike, 1 = Outbound Call, 2 = In/Outbound Call, 3 = Doorbell, 4 = LV-1K Control, factory set to 1)	1 digit (0-4)	then	#26
Relay Activation Tone (Buzz) Volume (1 digit 0-3, 0 = off, factory set to 3)	1 digit (0-3)	then	#27
Audio Detection Sensitivity (1-9, 1 = minimum, 9 = maximum, factory set to 5)	1 digit (1-9)	then	#28
In-Band Call Progress Detection (0 or 1, 0 = OFF, 1 = ON, factory set to 0)	1 digit (0 or 1)	then	#29
"Call Connected" LED Control (1 or 2, 1 = Automatic, 2 = Called Party Control / * entered to light LED, factory set to 1)	1 digit (1 or 2)	then	#30
Speaker Mode (0, 1 or 2, 0 = OFF/Silent Monitor, 1 = ON, 2 = OFF Until Answered, factory set to 1)	1 digit (0-2)	then	#31
LED Mode (0, 1 or 2, 0 = OFF, 1 = Entry Phone, 2 = Emergency Phone, 3 = Emergency Phone Outbound Only, factory set to 2)	1 digit (0-2)	then	#32
Auto Answer / Ring (0, 1 or 2, 0 = OFF, 1 = ON, 2 = OFF with Ringer Enabled, factory set to 1)	1 digit (0-2)	then	#33

DESCRIPTION	ENTER DIGITS
Diagnostic tones (used to check mic and speaker operation)	*0
Enable Alternate Switch Action (factory setting)	*1
Disable Alternate Switch Action	*2
Erase Message	*3
Record Message (enter # to stop recording)	*4
Playback Message	*5
Enable Latching Commands (factory setting)	*6
Disable Latching Commands	*7
To add a * at any point in the dialing string or relay command	**
To add a # at any point in the dialing string or relay command	*#
Reset all <b>Quick Programming Features</b> to factory default settings	###

# Programming Features

**Note:** Up to 32 digits can be stored in each dial position via touch tone programming, up to 255 characters via PC programming. Touch tone \* and # count as single digits.

## 1. Speed Dial Numbers (#00 - #09)

### A. Emergency Speed Dial Numbers (memory locations #00 - #04)

The emergency speed dial number programmed in location #00 is the number that is dialed when the "HELP" / "CALL" button is first pressed. Additional speed dial numbers will be dialed when there is no answer or a busy signal is detected and the next number redial features are activated. To program, enter the desired speed dial number followed by the location number (#00 - #04). To clear a speed dial location, simply enter the memory location (#00 - #04) alone. The 1600-IP Series phone is factory set with no speed dial number programmed.

To Program:	Enter:
*	**
#	*#
0, 1, 2 .... 9	0, 1, 2 .... 9

### B. "INFO" Speed Dial Numbers (E-1600-20/22/52/53-IP only) (memory locations #05 - #09)

The information speed dial number programmed in location #05 is the telephone or extension number that is dialed when the "INFO" button is first pressed (E-1600-20/22/52/53-IP). Additional information speed dial numbers will be dialed when there is no answer and the next number redial feature is activated. The 1600-IP Series phone will cycle through the programmed speed dial numbers until answered. To program, enter the desired speed dial number followed by the location number (#05 - #09). To clear a speed dial location, simply enter the location (#05 - #09) alone.

### C. Speed Dial Programming Examples

To Program the 1600-IP Series Phone...	Step 1	Step 2
...to store 555-1234 as the first emergency speed dial number	Enter Programming (see A. Accessing the Touch Tone Programming Mode, page 10)	Enter digits: 5 5 5 1 2 3 4 # 0 0
...to clear the first emergency speed dial number	Enter Programming (see A. Accessing the Touch Tone Programming Mode, page 10)	Enter digits: # 0 0

## 2. Talk / Listen Delay (#11)

This feature selects switching time between talk and listen modes (VOX switching time). Use chart at the right.

\* **Note:** The factory default is .5 seconds.

Touch Tone	Talk/Listen Delay
1	.1 sec
2	.2 sec
3	.3 sec
4	.4 sec
5	.5 sec *
6	.6 sec
7	.7 sec
8	.8 sec
9	.9 sec

## 3. Call Length Time Out (#12)

This feature selects the maximum length of time that calls can be connected. Programmable in increments of 1 minute up to a maximum of 9 minutes (Touch Tones 1 - 9). Program 0 in this location to disable the call length time out. With the call length disabled, the 1600-IP Series phone must rely on a CPC signal, busy signal, silence or return to dial tone to hang-up. Use chart at the right.

\* **Note:** The factory default is 3 minutes.

Touch Tone	Call Length Time Out
0	Disabled
1	1 min
2	2 min
3	3 min*
4	4 min
5	5 min
6	6 min
7	7 min
8	8 min
9	9 min

#### 4. Repeat Announcement Option (#15)

The **1600-IP Series** phone can be programmed to play the announcement from 1-9 times, or to continuously repeat the announcement every 8 seconds until a Touch Tone \* is detected from the distant party. The call connected LED will turn on automatically after the announcement has stopped repeating.

\* **Note:** The factory default for the **1600-IP Series** phone is to play the voice announcement one time.

Touch Tone	Repeat Announcement
0	Repeat every 8 seconds
1	1 time*
2	2 time
3	3 time
4	4 time
5	5 time
6	6 time
7	7 time
8	8 time
9	9 time

#### 5. Lap Counter (#16)

With the lap counter disabled (factory setting), if the **1600-IP Series** phone is programmed to dial the next number on ring-no-answer and/or busy signal (see section **F** and **G** below), the **1600-IP Series** phone will continuously call its programmed phone numbers forever until the call is answered.

The lap counter is a programmable counter that determines how many times the **1600-IP Series** phone will cycle through its list of up to 5 emergency numbers (or up to 5 "Info" phone numbers), before it stops the dialing process and hangs up. When all of the programmed phone numbers have been dialed, the lap counter is incremented and the dialing process repeats. When the lap counter has been met, the dialing process stops and the **1600-IP Series** phone hangs up.

\* **Note:** This feature is disabled in the factory default setting.

Touch Tone	Lap Counter
0	Disabled*
1	1 time
2	2 time
3	3 time
4	4 time
5	5 time
6	6 time
7	7 time
8	8 time
9	9 time

#### 6. Dial Next Number on Ring No Answer (#17)

If enabled and a ring-no-answer is detected, the **1600-IP Series** phone will dial the next programmed speed dial number, and continue to cycle through the emergency numbers until a call is completed.

\* **Note:** Factory set to redial if not answered after 7 rings.

Touch Tone	Ring No Answer
0	Disabled
1	Disabled
2	2 rings
3	3 rings
4	4 rings
5	5 rings
6	6 rings
7	7 rings*
8	8 rings
9	9 rings

#### 7. Dial Next Number on Busy (#18)

If enabled and a busy is detected, the **1600-IP Series** phone will dial the next programmed speed dial number, and continue to cycle through the numbers until a call is completed.

\* **Notes:** This feature is enabled in the factory default setting. If the busy signal is interrupted with a promotional message, contact your central office to have it removed.

Touch Tone	Dial on Busy
1	Disabled
2	Enabled*

#### 8. Identification Number (#20)

The Touch Tone I.D. number (up to 6 digits) is used by emergency personnel to identify the location of the caller and is given out when the receiving party presses a Touch Tone \*. The security office can display the number using a Touch Tone decoder. To program the I.D. number, enter the desired number followed by #20. **Example:** To store 333 as the I.D. number, enter: **3 3 3 # 2 0**

#### 9. Access Code (#21)

The Access Code is used for remotely operating the relay (Doorstrike, Mag-Lock, etc) by calling into the unit. This code provides basic security and only allows operation of the relay and not the ability to change any of the programming parameters. Once entered, any of the "Remote Access Operation Commands" can be used. The code can be 1 to 6 digits in length and cannot contain a "\*" or "#". To disable the Access Code enter no digits then #21 in programming. Simply call the **1600-IP Series** phone, the unit will automatically answer the line and output a single beep. You then enter the programmed 1 to 6 digit access code, 2 beeps should be heard. You can now enter any "Remote Access Operation Commands" (see page 17).

## 10. Mic Volume/Automatic Noise Cancelling Mode (#22)

The microphone volume can be set from 1 to 9 (1 = lowest volume setting, 9 = the highest, factory set to 5) by entering the single digit then the memory location **#22**. Alternatively the microphone can be placed in the “ANC” Automatic Noise Cancelling mode by entering **0#22** in programming. With the mic in the ANC mode, when background noise increases the mic gain will automatically decrease. When background noise decreases the mic gain will automatically increase. The ANC mode is useful in applications where the background noise level can change drastically such as a gas car running vs a diesel truck.

## 11. Speaker Volume (#23)

The speaker volume can be set from 0 to 9 (0 = lowest volume setting, 9 = the highest, factory set to 5) by entering the single digit then the memory location **#23**. Alternatively the speaker can be turned off for silent monitoring by entering **0#31** (see Speaker Mode section 19).

## 12. Relay Activation Command (#24)

The one or two digit code stored in the Relay Activation Command is the touch tone command that the person being called must enter on their phone in order to actuate the relay (door strike/mag-lock/gate controller, etc). The code can contain the numbers 0 - 9, 00 - 99, ## or \*\* (factory default). To program the code to “##” you must enter **\*\*\*# #24** in programming. To program the code to “\*\*” you must enter **\*\*\*\* #24** in programming. To disable this feature enter **#24** without any preceding digits. The code must be entered while the remote phone is communicating with the Emergency/Entry phone. The Emergency/Entry phone determines which direction the touch tone is coming from and only responds to touch tones from the called phone.

## 13. Relay Activation Time (#25)

The value stored in the Relay Activation Time is the amount of time the relay will be energized after a correct touch tone command is entered. This two digit number can range from 01 to 99 seconds, or enter 00 for 0.5 seconds. The factory setting is 5 seconds.

## 14. Relay Mode (#26)

The 2 amp relay contacts can be programmed to one of five different modes by entering **0,1,2,3 or 4 #26** in programming.

**0 = Doorstrike Mode.** When programmed for Doorstrike Mode the relay will momentarily activate for the preprogrammed relay activation time after detecting the correct relay activation command (one or two digit touch tone) from the called party.

**1 = Outbound Call Mode.** When programmed for Outbound Call Mode the relay will activate continuously for the duration of any outbound call from the Emergency/Entry phone. This mode is useful for activating strobe lights for Emergency VoIP phones.

**2 = Inbound/Outbound Call Mode.** When programmed for Inbound/Outbound Call Mode the relay will activate continuously for the duration of any inbound or outbound call from the Emergency/Entry phone. This mode is useful for turning on IR flood lights for VoIP phones with cameras, etc.

**3 = Doorbell Mode.** When programmed for Doorbell Mode the relay will momentarily activate the relay for the preprogrammed relay activation time on any outbound call from the Emergency/Entry phone. This mode is useful for activating a door chime, etc. When activating door chimes, a 0.5 - 1 second relay activation time is recommended.

**4 = LV-1K Control Mode.** When programmed for LV-1K Control Mode the relay will activate continuously while the Emergency/Entry phone is powered and registered to the SIP server. In the event the unit loses power and/or SIP registration the relay will turn off, activating LV-1K’s flashing LED and audible beep signals.

## 15. Relay Activation Tone (Buzz) Volume (#27)

The relay activation tone is a buzzing sound that is heard at the Emergency/Entry phone and in the called phone when the door strike relay is activated. The tone length will match the relay activation time up to a maximum of 5 seconds. The tone can be programmed to three different volume settings 1 = Low, 2= Medium, 3 = High in memory location **#27**. The tone can also be turned off/disabled by entering **0#27**.

## 16. Audio Detection Sensitivity (#28)

The Audio Detection Sensitivity can be set from 1 to 9 (1 = minimum setting, 9 = the highest, factory set to 5) by entering the single digit then the memory location **#28**. Increasing or decreasing the sensitivity may be required in applications where you are making an outbound call through your VoIP phone system and are relying on analog audio detection of the distant party answering to turn on the call connected LED and/or play the location ID message on Emergency VoIP phones.

## 17. In-Band Call Progress Detection (#29)

The In-Band Call Progress Detection can be set to 0 or 1 (0 = OFF, 1 = ON, factory set to 0) by entering the single digit then the memory location **#29**. In-Band Call Progress detection should be turned ON in applications where you are making an outbound call through your VoIP phone system and are relying on analog audio detection of the distant party answering to turn on the call connected LED and/or play the location ID message on Emergency VoIP phones.

## 18. “Call Connected” LED Control (#30)

The call connected LED on the **1600-IP Series** phone can be programmed to:

**1** = LED will automatically light when the distant party has answered, this is the factory default setting.

**2** = LED will light steady, only after a Touch Tone \* is entered from the called party.

## 19. Speaker Mode (#31)

The Speaker Mode can be set to one of three modes.

**0 = OFF/Silent Monitoring Mode:** In the “OFF” mode the speaker is disabled at all times. However, the speaker can be enabled after communication has been established by entering touch tone command “**9#**”. The speaker will remain on for the duration of the call.

**1 = ON (factory setting):** In the “ON” mode the speaker is enabled during In-bound and Out-bound calls.

**2 = OFF Until Answered:** In the “OFF Until Answered” mode the speaker will remain silent during dialing and will not turn on until the called party has answered.

## 20. LED Mode (#32)

The “Call / Call Connected” LED can be programmed to one of three different modes: 0/OFF, 1/Entry Phone (factory setting), or 2/Emergency Phone.

**0 = OFF Mode:** Useful for silent monitoring applications. In this mode the LED will not light during normal operation. It will only light (blink) if it cannot register with the programmed SIP server or while manually resetting the security code.

**1 = Entry Phone Mode:** The LED will remain ON in the idle state, turn off while button is pressed, blink during dialing, light steady when the call is answered, then turn OFF momentarily when the call is completed.

**2 = Emergency Phone Mode:** The LED will remain OFF in the idle state, blink during dialing, light steady when the call is connected, then turn OFF when the call is completed.

**3 = Emergency Phone Outbound Only:** On outbound calls, the LED will remain OFF in the idle state, blink during dialing, light steady when the call is connected, then turn OFF when the call is completed. On in-bound calls, the LED will remain off. This is useful for silent monitoring on inbound calls.

## 21. Auto Answer / Ring (#33)

The Auto Answer/Ring feature can be set to one of three modes.

**0 = OFF:** In the “OFF” mode the phone will not automatically answer an incoming call.

**1 = ON (factory setting):** In the “ON” mode the phone will automatically answer an incoming call on the first ring.

**2 = OFF with Ringer Enabled:** In the “OFF with Ringer Enabled” mode the phone will not automatically answer a incoming call but will output a loud ring signal out of the speaker in a 2 seconds on, 4 seconds off ring pattern. The call can then be answered by pressing the Help/Call button.

## 22. Enable/Disable Alternate Switch Action (\*1, \*2)

With “\*1” (factory default) programmed the HELP/CALL button alternately connects and disconnects calls. With “\*2” programmed the HELP/CALL button connects calls only. Pressing the button again after the call has been initiated will not terminate the call.

## 23. Recording the Announcement

<b>Step 1.</b>	Call into the <b>1600-IP Series</b> phone with a Touch Tone phone and access programming.
<b>Step 2.</b>	Enter *4, wait for the tone and then begin recording (28 seconds of record time is available).
<b>Step 3.</b>	Enter # to stop the recording. Playback is automatic.
<b>Step 4.</b>	Enter *5 to review the announcement again.
<b>Step 5.</b>	If you choose to not use a voice announcement, enter *3 to clear the recording.

**Example:** “Elevator number 1215, located in the Financial Building, needs assistance. Press the star (\*) key on your telephone to hear this announcement again.”

## 24. Enable/Disable Latching Commands (\*6, \*7)

With “\*6” (factory default) programmed the Remote Access Operation Commands (\*0 and \*1) to Un-Latch or Latch the relay are enabled.

With “\*7” programmed the Remote Access Operation Commands (\*0 and \*1) to Un-Latch or Latch the relay are disabled. Disabling the Latch commands can be useful in applications where you want to eliminate the possibility of inadvertently entering a latch command leaving a gate open/closed, etc.

## 25. Reset All Quick Programming Features (###)

Entering ### in programming will reset all of the Quick Programming Features back to their factory default settings. **Note:** The ### command will not change or reset your IP settings.



## Operation

### A. “HELP” / “CALL” Button

When the “HELP” / “CALL” button is pressed, the **1600-IP Series** phone dials a pre-programmed telephone number. The Call Connected LED momentarily flashes during dialing. In the event the line is busy or there is a ring-no-answer, the unit can be programmed to call additional phone numbers.

The phone then cycles through up to 5 pre-programmed emergency numbers until the call is answered. When the call is answered, the digital voice announcer will automatically play to identify the location of the emergency call. The phones are factory programmed to play the announcement once, and then automatically light the “Call Connected” LED to show that handsfree communication to emergency personnel is established. The \* key will send the I.D. number (if programmed), and play the announcement again. The distant party will know the location of the emergency call by either the voice announcement or by decoding the Touch Tone I.D. number. Once the “Call Connected” LED is on, the # key can be used to force the phone to hang-up.

### B. “INFO” Button (E-1600-20/22/52/53-IP)

When the “INFO” button is pressed (**E-1600-20/22/52/53-IP** only), the phone goes off-hook and dials the first “INFO” phone number programmed. If a busy signal is detected or the call goes unanswered, the phone will cycle through all five “INFO” phone numbers until the call is answered. When answered, handsfree communication is established. **Note:** *The voice announcement is for **Emergency/Help** calls only and will not play on a call initiated from the “INFO” button.*

### C. Remote Access Operation Commands

The following commands can be entered after answering an inbound call from the emergency phone. The commands can also be entered on an outbound call to the emergency phone. After the emergency phone auto answers the call, two beeps will be heard. If the access code has been disabled, you can now enter the Remote Access Operation Commands below. If an Access code has been programmed, enter the Access code digits. With the correct code entered, two beeps will be heard and you can now enter the Remote Access Operation Commands below.

Feature	Tone Tone Command	Description
Activate Relay	** or ____	Momentarily activate relay (1 or 2 digits, factory set to **).
Un-Latch Relay	*0	Un-latch* (deactivate) the relay.
Latch Relay	*1	Latch* (continuously activate) the relay.
Disconnect	#	Disconnects or forces the emergency phone to hang up.
Send ID and Play Message	*	Send I.D. number (if programmed) and plays the announcement.

\* **Note:** *Latching commands must be enabled (\*6) in programming.*

## Troubleshooting

If the unit cannot register with the programmed SIP server, the LED will blink on and off every two seconds, and three error beeps will be heard every 30 seconds until communication is restored. This alerts a potential user of a problem with the device that will prevent an emergency phone call from being made.

You may silence the error beeps per instance by pressing and holding the HELP/CALL button for 5 seconds or by clicking the “Mute Alarm Until Next Failure” button in the Viking VoIP Programming Software (see section **A** on page 10). The error beeps automatically re-enable once the unit is registered, to alert of any new problems that arise.

## Line Verification Panel with Key Switch

New ASME A17.1-2010 code requires that “the two-way communications means within the (elevator) car shall include a means to verify operability of the LAN connection”. When your local municipality adopts this new ASME A17.1 code the **LV-1K** can be added to fulfill all requirements for visual and audible signaling when it is determined the telephone line is not functioning.

The **LV-1K** can be added to any new or existing Viking **1600-IP Series** elevator emergency as a single phone stand alone solution. The **LV-1K** continuously monitors for loss of PoE or communication with the server and will immediately provide an audible and visual indication when the LAN connection has been accidentally cut or disconnected.

In accordance to ASME A17.1, the **LV-1K** is labeled “ELEVATOR COMMUNICATION FAILURE” in ¼” high red letters, and will sound an audible signal every 30 seconds and flash a red light when a loss of connection is detected. Authorized personnel can silence the audible signal with the included key switch. The LED will remain flashing until the fault is corrected.



For more information, see DOD# 246

## Surface or Pedestal Mount Viking Products While Maintaining Weather and Vandal Resistance

The **VE-3x5**, **VE-5x5**, **VE-6x7** and **VE-5x10** add vandal and weather resistance, as well as versatility to many Viking products. The **VE-Series** backboxes are available in black fine texture powder painted steel or Marine Grade 316 stainless steel. The weather resistant boxes are designed to be surface mounted to a wall, post, single gang box, or a **VE-GNP** gooseneck pedestal. **Note:** The **VE-3x5** is not compatible with the **VE-GNP** pedestals and is not available in stainless steel.

The **VE-3x5** is designed to be used with the **E-40-EWP** or **E-50-EWP** Series entry phones. The **VE-5x5** is designed to be used with the **E-10A-EWP**, **E-30-EWP**, **E-30-PT-EWP**, **E-60-EWP**, **E-65-EWP**, **E-70-EWP**, **E-75-EWP** entry phones, the **E-1600-20A-EWP**, **E-1600-20-IP-EWP**, **E-1600-30A-EWP** and **E-1600-30-IP-EWP** emergency phones, as well as the **W-1000-EWP** and **W-3000-EWP** handsfree doorboxes. The **VE-6x7** is designed to be used with the **K-1700-3-EWP** and **K-1705-EWP** entry phones and the **VE-5x10** is designed to be used with the **K-1900-7-EWP** and the **K-1900-8-EWP** vandal resistant phones.

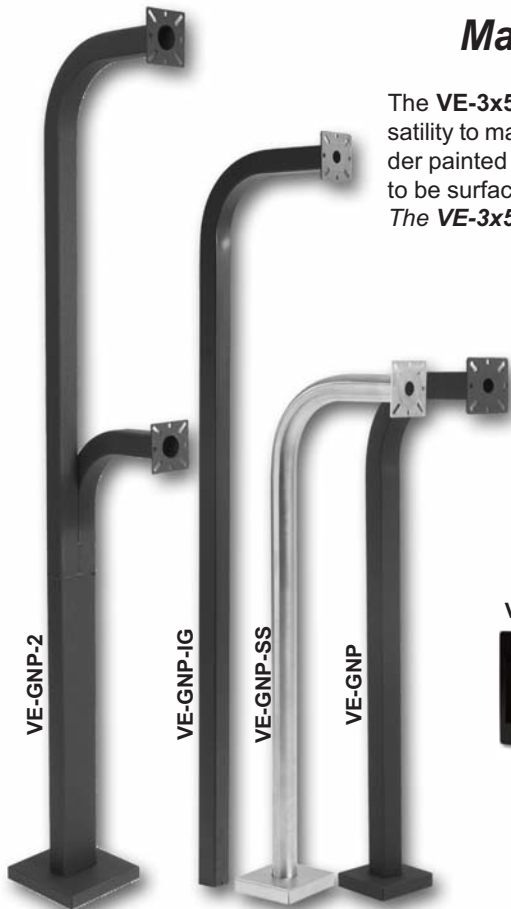

For more information, see DOD# 424

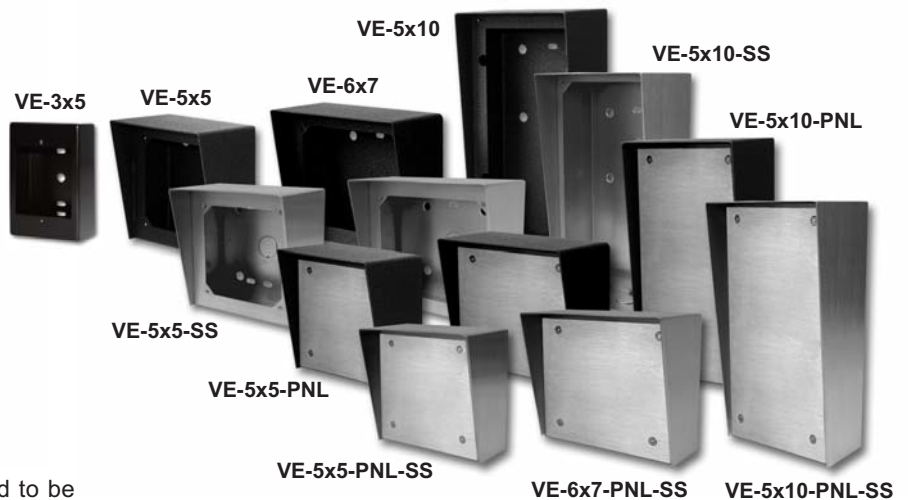

The **VE-GNP** gooseneck pedestals are designed to be used with the **VE-5x5**, **VE-6x7** and **VE-5x10** backboxes and are ideal for drive up communications. **Note:** The **VE-3x5** is not compatible with the **VE-GNP** pedestals. The **VE-PNL**'s are **VE-Series** backboxes with a blank aluminum panel. The user can customize the clear-coated aluminum panel to mount an **PRX-1** card reader, **PRX-2** keypad or switch. The kits come complete with box, gasket, panel and screws. Model numbers that end with “SS” are stainless steel version. **Note:** The use of magnets to mount the **VE-Series** enclosure to a metal surface can affect the operation of the enclosed product.

## Viking Area of Refuge Signs Designed to Comply with IBC, ADA, NFPA and ICC Requirements



**ARS-TB100**

Tactile Blue Braille and raised letter sign to be placed next to the Area Of Refuge (stairwell exit) door.



**ARS-IB100**

Instructional Blue Braille and Raised letter sign to be placed next to the Area of Refuge emergency phone (E-1600A-IP, etc.)



**ARS-LR100**

Lighted double sided Wall or ceiling mount sign to be placed above the Area Of Refuge (stairwell exit) door.



**ARS-DLB100**



**ARS-DRB100**

Directional Blue signs with left or right arrow to be placed next to exit doors without Area Of Refuge.

- **ARS-LR100:** Red LED edge lit wall sign, 120/277V AC power, Included NiCad battery delivers over 3 hours of battery backup, UL listed, Universal wall, side or ceiling mounting, Silver aluminum housing with mirrored double sided acrylic sign surface, Battery test button, AC pwr LED, Low voltage automatic battery disconnect to prevent deep cycling battery, mounting hardware and 4 optional Chevron arrows with mounting templates included.
- **ARS-TB100:** 6" wide x 9" tall Tactile Sign with 0.031" raised white letters and accessibility symbol, California compliant Contrated Grade 2 Braille. Blue PMS 300 Acrylic with non-glare finish, 0.032" thick double sided foam included.

- **ARS-IB100:** 6" wide x 7.5" tall Instructional sign with 0.031" raised white "Push For Help" letters and ingraved white text, California compliant Contrated Grade 2 Braille. Blue PMS 294 ABS with non-glare finish, 0.032" thick double sided foam included.
- **ARS-DLB100** (left arrow) and **ARS-DRB100** (right arrow): 12" wide x 4" tall Directional sign with ingraved white text, Blue PMS 294 ABS with non-glare finish, 0.032" thick double sided foam included.
- **VE-ARSW:** Area of Refuge surface mount command center cabinet. Lockable for mounting "Two-Way Communications System" phone in low rise (less than 60 ft tall) buildings. See **DOD# 237**.

The **ARS Series** Area of Refuge Signs are designed comply with IBC 1007,1011, ADA 4.3.11, NFPA 22, 101 and ICC 703 code requirements. The **ARS-LR100** is an LED Illuminated edge-lit double sided hanging Sign. It is AC powered with 3 hour battery backup. The unit can be ceiling mounted, mounted flat against a wall or end mounted so it can be viewed from either direction. The Instructional, Tactile and Directional signs are made from Acrylic or durable ABS plastic and are designed to adhere to the wall with the provided double sided foam tape. **For more information, see DOD# 235.**

# Warranty

## IF YOU HAVE A PROBLEM WITH A VIKING PRODUCT, CONTACT: VIKING TECHNICAL SUPPORT AT (715) 386-8666

Our Technical Support Department is available for assistance Monday 8am - 4pm and Tuesday through Friday 8am - 5pm central time. So that we can give you better service, before you call please:

1. Know the model number, the serial number and what software version you have (see serial label).
2. Have your Technical Practice in front of you.
3. It is best if you are on site.

### RETURNING PRODUCT FOR REPAIR

The following procedure is for equipment that needs repair:

1. Customer must contact Viking's Technical Support Department at 715-386-8666 to obtain a Return Authorization (RA) number. The customer MUST have a complete description of the problem, with all pertinent information regarding the defect, such as options set, conditions, symptoms, methods to duplicate problem, frequency of failure, etc.
2. Packing: Return equipment in original box or in proper packing so that damage will not occur while in transit. Static sensitive equipment such as a circuit board should be in an anti-static bag, sandwiched between foam and individually boxed. All equipment should be wrapped to avoid packing material lodging in or sticking to the equipment. Include ALL parts of the equipment. C.O.D. or freight collect shipments cannot be accepted. Ship cartons prepaid to: **Viking Electronics, 1531 Industrial Street, Hudson, WI 54016**
3. Return shipping address: Be sure to include your return shipping address inside the box. We cannot ship to a PO Box.
4. RA number on carton: In large printing, write the R.A. number on the outside of each carton being returned.

### RETURNING PRODUCT FOR EXCHANGE

The following procedure is for equipment that has failed out-of-box (within 10 days of purchase):

1. Customer must contact Viking's Technical Support at 715-386-8666 to determine possible causes for the problem. The customer MUST be able to step through recommended tests for diagnosis.
2. If the Technical Support Product Specialist determines that the equipment is defective based on the customer's input and troubleshooting, a Return Authorization (R.A.) number will be issued. This number is valid for fourteen (14) calendar days from the date of issue.
3. After obtaining the R.A. number, return the approved equipment to your distributor, referencing the R.A. number. Your distributor will then replace the Viking product using the same R.A. number.
4. **The distributor will NOT exchange this product without first obtaining the R.A. number from you. If you haven't followed the steps listed in 1, 2 and 3, be aware that you will have to pay a restocking charge.**

### TWO YEAR LIMITED WARRANTY

Viking warrants its products to be free from defects in the workmanship or materials, under normal use and service, for a period of two years from the date of purchase from any authorized Viking distributor. If at any time during the warranty period, the product is deemed defective or malfunctions, return the product to Viking Electronics, Inc., 1531 Industrial Street, Hudson, WI., 54016. Customer must contact Viking's Technical Support Department at 715-386-8666 to obtain a Return Authorization (R.A.) number.

This warranty does not cover any damage to the product due to lightning, over voltage, under voltage, accident, misuse, abuse, negligence or any damage caused by use of the product by the purchaser or others. This warranty does not cover non-EWP products that have been exposed to wet or corrosive environments. This warranty does not cover stainless steel surfaces that have not been properly maintained.

**NO OTHER WARRANTIES.** VIKING MAKES NO WARRANTIES RELATING TO ITS PRODUCTS OTHER THAN AS DESCRIBED ABOVE AND DISCLAIMS ANY EXPRESS OR IMPLIED WARRANTIES OR MERCHANTABILITY OR FITNESS FOR ANY PARTICULAR PURPOSE.

**EXCLUSION OF CONSEQUENTIAL DAMAGES.** VIKING SHALL NOT, UNDER ANY CIRCUMSTANCES, BE LIABLE TO PURCHASER, OR ANY OTHER PARTY, FOR CONSEQUENTIAL, INCIDENTAL, SPECIAL OR EXEMPLARY DAMAGES ARISING OUT OF OR RELATED TO THE SALE OR USE OF THE PRODUCT SOLD HEREUNDER.

**EXCLUSIVE REMEDY AND LIMITATION OF LIABILITY.** WHETHER IN AN ACTION BASED ON CONTRACT, TORT (INCLUDING NEGLIGENCE OR STRICT LIABILITY) OR ANY OTHER LEGAL THEORY, ANY LIABILITY OF VIKING SHALL BE LIMITED TO REPAIR OR REPLACEMENT OF THE PRODUCT, OR AT VIKING'S OPTION, REFUND OF THE PURCHASE PRICE AS THE EXCLUSIVE REMEDY AND ANY LIABILITY OF VIKING SHALL BE SO LIMITED.

IT IS EXPRESSLY UNDERSTOOD AND AGREED THAT EACH AND EVERY PROVISION OF THIS AGREEMENT WHICH PROVIDES FOR DISCLAIMER OF WARRANTIES, EXCLUSION OF CONSEQUENTIAL DAMAGES, AND EXCLUSIVE REMEDY AND LIMITATION OF LIABILITY, ARE SEVERABLE FROM ANY OTHER PROVISION AND EACH PROVISION IS A SEPARABLE AND INDEPENDENT ELEMENT OF RISK ALLOCATION AND IS INTENDED TO BE ENFORCED AS SUCH.

If trouble is experienced with the **1600-IP Series** phone, for repair or warranty information, please contact:

**Viking Electronics, Inc., 1531 Industrial Street, Hudson, WI 54016 (715) 386-8666**

### WHEN PROGRAMMING EMERGENCY NUMBERS AND (OR) MAKING TEST CALLS TO EMERGENCY NUMBERS:

Remain on the line and briefly explain to the dispatcher the reason for the call. Perform such activities in the off-peak hours, such as early morning or late evenings.

### PART 15 LIMITATIONS

This equipment has been tested and found to comply with the limits for a Class A digital device, pursuant to Part 15 of the FCC Rules. These limits are designed to provide reasonable protection against harmful interference when the equipment is operated in a commercial environment. This equipment generates, uses, and can radiate radio frequency energy and, if not installed and used in accordance with the instruction manual, may cause harmful interference to radio communications. Operation of this equipment in a residential area is likely to cause harmful interference in which case the user will be required to correct the interference at his own expense.

**Product Support: (715) 386-8666**

Due to the dynamic nature of the product design, the information contained in this document is subject to change without notice. Viking Electronics, and its affiliates and/or subsidiaries assume no responsibility for errors and omissions contained in this information. Revisions of this document or new editions of it may be issued to incorporate such changes.